

Check Valve

Single Door Check Valve PN10-40

FEATURES:

- Investment Casting Body
- Flange Standard: PN10/25/40
- Viton Sealing And Metal Sealing Available
- Material: CF8M/CF8/SS316/SS304/1.4408/1.4301
- Maximum Working Temperature: -20-520 °C

NO.	PART NAME	MATERIAL	
1	Body	CF8M	CF8
2	Plant Seat	VITON	FKM
3	Disc	SUS316	SUS304
4	Bolt	SS304	
5	O-Ring	VITON	
6	Handle	SUS304	

Size	2"	2-1/2"	3"	4"	5"	6"	8"	10"	12"
ød	30	40	52	72	93	115	157	195	230
L	19	19	19	19	19	19	29	29	38
øC	108	128	143	163	193	219	274	329	380
H	105	120	145	150	170	195	260	300	320

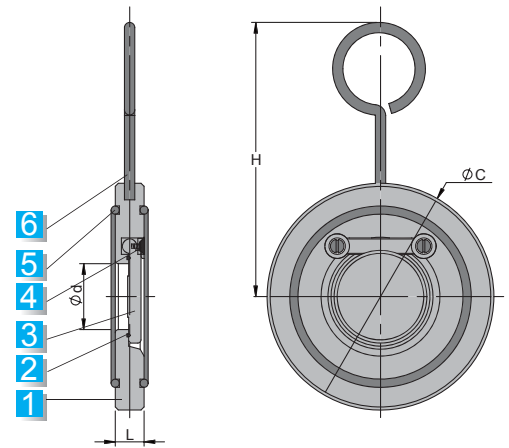

Swing Check Valve Class 200

FEATURES:

- Investment Casting Body
- Swing Type
- Viton Sealing And Metal Sealing Available
- Material: CF8M/CF8/SS316/SS304/1.4408/1.4301
- Maximum Working Temperature: 400 °C

NO.	PART NAME	MATERIAL		
1	Disc	CF8M	CF8	WCB
2	Body	CF8M	CF8	WCB
3	Pin	SS316	SS304	
4	Seat	PFTE		
5	Cap	CF8M	CF8	WCB
6	Washer	SS304		
7	Bolt	SS304		

Size	1/4"	3/8"	1/2"	3/4"	1"	1-1/4"	1-1/2"	2"	2-1/2"	3"
L	65	65	65	80	89	105	120	139	181	200
ød	6	10	15	20	25	32	40	50	65	80
H	43	43	43	50	60	66	75	80	99	104
C	47	47	47	56	64	64	75	84.5	111	152

